



SAS EPI
ZI DES DES BEAUX SOLEILS
09 CHAUSSEE JULES CESAR
95520 OSNY - FRANCE
TEL :+33 1 30 75 11 67
FAX: +33 1 30 75 12 67
contact@epi-groupe.com
www.epigroupe.com

上海苏虞铁路配件有限公司

Shanghai SUYU RailWay EPI Groupe Material Co

WHERE THERE IS A RAILWAY
THERE WE ARE



目录

CONTENTS

9	钢轨配件组合 Rail fastening system
11	螺纹道钉 Screw Spike
16	钩头道钉 Track spike
18	螺栓 Railway bolt
25	弹条 Elastic Clip
31	防爬器 Rail anchor
32	扣板 Rail Clip
34	预埋件 Rail Shoulder
35	鱼尾板 Fish Plate
36	铁垫板 Tie plate / Base plate
38	垫圈 Washer
40	螺母 Nut
41	塑料和橡胶制品 Plastic and rubber part
43	闸瓦 Brake block
44	起重轨 Crane rail

上海苏虞铁路配件有限公司成立于2003年，在中国铁路紧固件行业中是首屈一指的领头羊。苏虞公司总部位于上海，工厂坐落在紧邻上海的江苏省昆山市，交通便捷。

我们通过ISO 9001:2008质量管理体系认证，有一整套完备的质量检测设备，严格控制每一道生产工序，确保所有产品严格达到国际标准和客户要求。

苏虞团队由一批国有铁路公司的高层专家组成，5位资深工程师，20位专业技术人员和一批具有丰富经验的一线生产工人。我们有自己的研发部，售后服务部，以先进技术和管理理念为宗旨的质量保证团队给予客户最忠诚的服务。

伴随着先进的技术，齐全的检测设备，强大的生产能力和优质的服务，苏虞产品远销海内外，并通过了BV,SGS, ABS等国际知名检测机构的多次检测，我们先后给哈萨克斯坦铁路局、赞比亚铁路局、泰国铁路局、印尼铁路局、马来西亚铁路局、瑞典铁路局、新西兰铁路局、美国铁路局、加拿大铁路局等供过货，质量受到他们的高度好评。

我们可以按照美标，德标，英标，日标，法标等国际标准生产各种标准产品，除此之外，苏虞高标准的研发部门致力于按照客户图纸和样品开发各种非标产品。

秉承“锲而不舍，追求卓越”的企业精神，以“为世界提供最高质量的铁路产品”为理念，苏虞将成为您最忠实可靠的合作伙伴。我们期待与您合作，共创美好未来！

Founded in 2003, SUYU is now a leading and reputed manufacturer of qualified railway fasteners in China. With its headquarter in Shanghai Pudong and factory in Suzhou Province, Kunshan City.

We are certified by ISO 9001:2008. We have a complete set of inspection equipments to strictly control the quality of each production procedure and make sure all the products reach international standards and customers' requirements.

SUYU team is composed of high professional experts from former state railway companies. We have 5 senior engineers, 20 professional technicians and a group of highly experienced operation workers. We have our own R&D team, after-sales service team and quality-assurance team with the most advance technology and management concepts.

With advanced technology, powerful processing capacity and excellent service, our products have been exported worldwide. After many times of inspections by BV, SGS, ABS etc, our products have been well recognized by our customers. We are qualified supplier of Kazakhstan railway, Zambia Railway, Thailand Railway, Indonesia Railway, Malaysia Railway, Sweden Railway, New Zealand Railway, American Railway, Canada Railway etc, supplying all kinds of railway material to them for many years without any quality complaint.

We can produce according to International standards like ASTM, DIN, BS, JIS, AS, NF, ISO, GB. Besides, we have our own high standard R&D department, willing to develop all kinds of non-standard products according to customers' drawings or samples.

SUYU people will keep on working hard and make all their efforts to make SUYU a global-famous factory in the international railway market.

Working under the spirit of "Persisting and Pursuing Excellence", with the idea of "supplying first-class railway materials to the world, SUYU would always like to be your strongest and most reliable partner. We sincerely believe we can build a bright future with your cooperation!





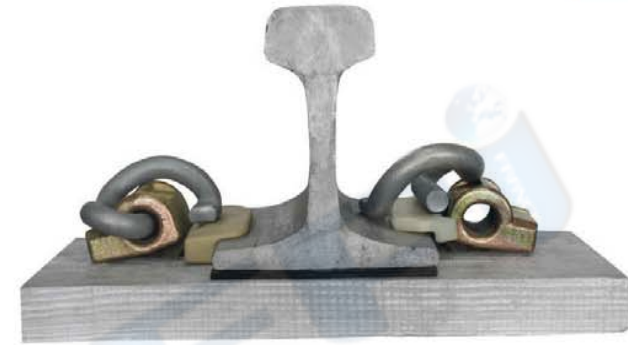

1 钢轨配件组合 Rail fastening system

- 1) E Type Rail Fastening
- 2) KPO Rail Fastening
- 3) Nabla Rail Fastening

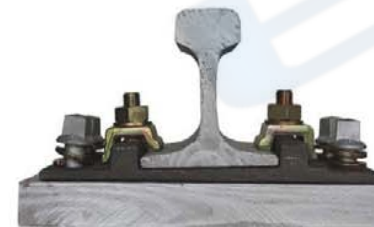
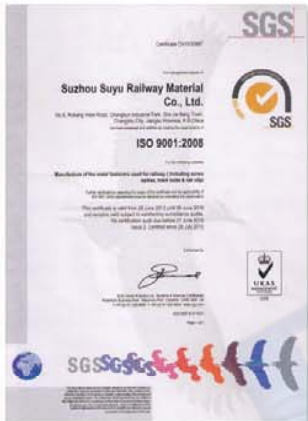



• 公司产品 (螺纹道钉) •
 COMPANY PRODUCTS Screw spike

2

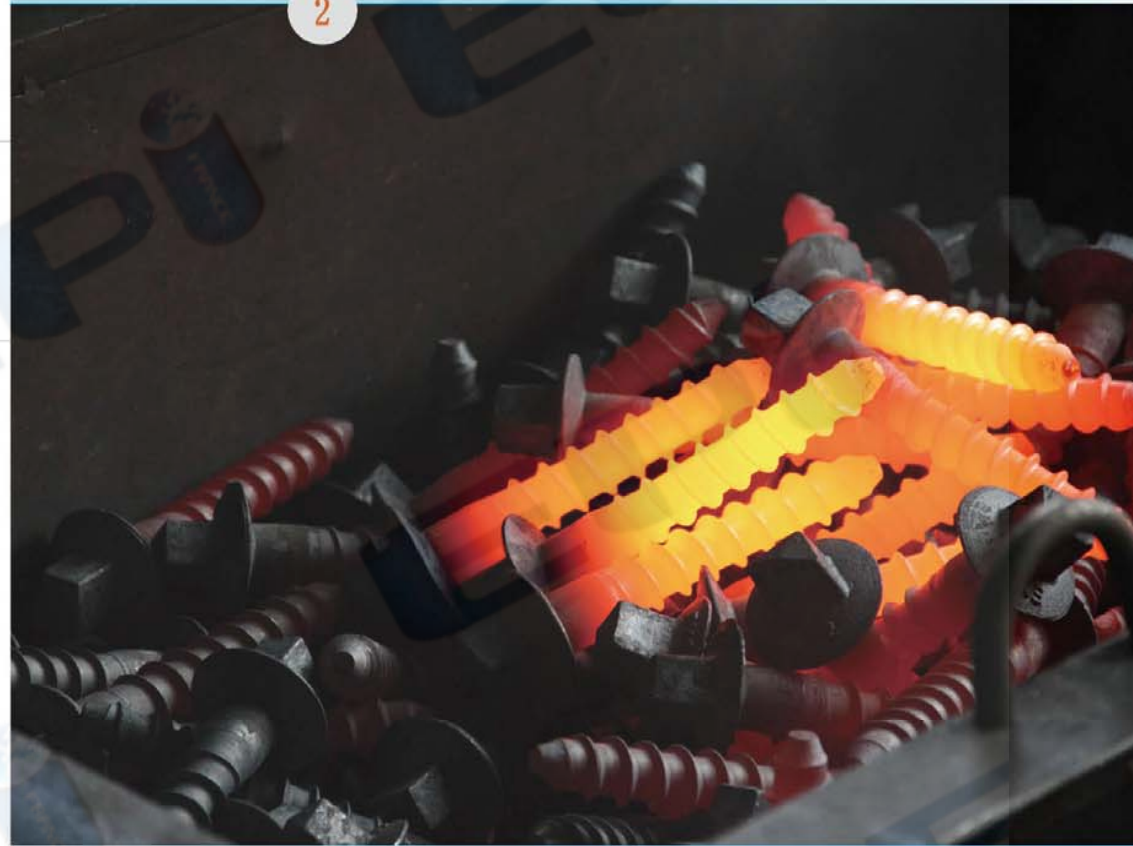

1 钢轨配件组合 Rail fastening system

- 4) SKL14 Rail Fastening
- 5) SKL3 Rail Fastening 6) SKL12 Rail Fastening



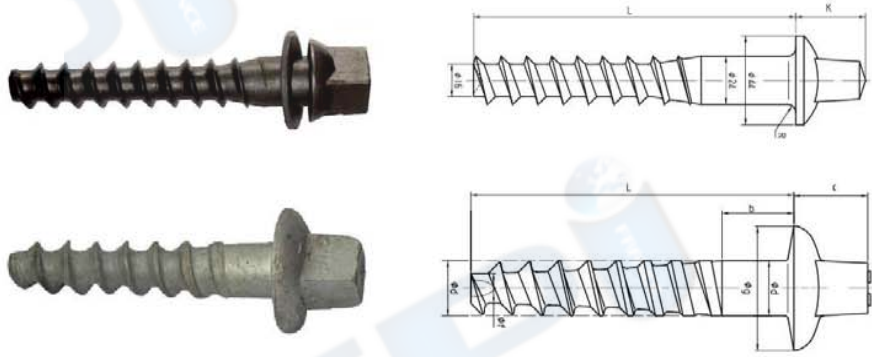

螺纹道钉 Screw spike

- 1) Ss series according to UIC864-1
- 2) 3V Sleeper screw as per NF F50006
- 3) TR thread screw spike
- 4) Screw spike for Metro

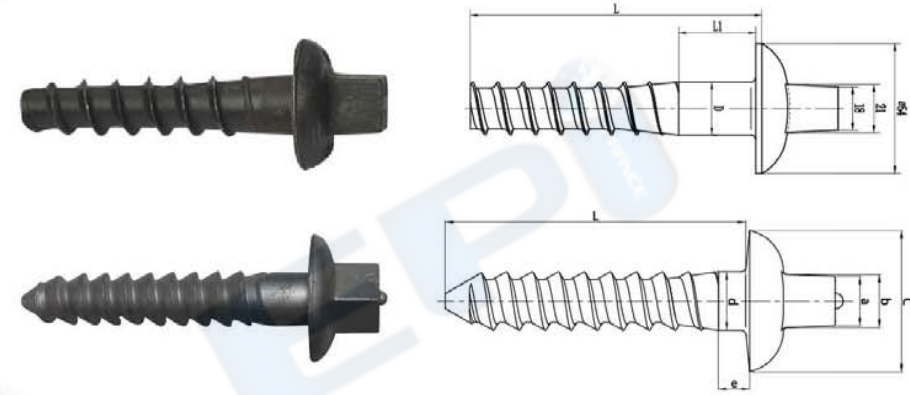

螺纹道钉 Screw spike

- 5) Screw spike for South American
- 6) Screw spike with big disk for Africa
- 7) High tensile screw spike

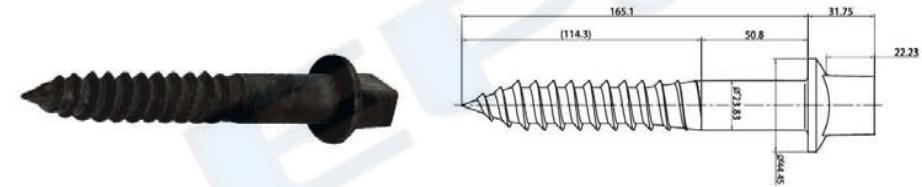
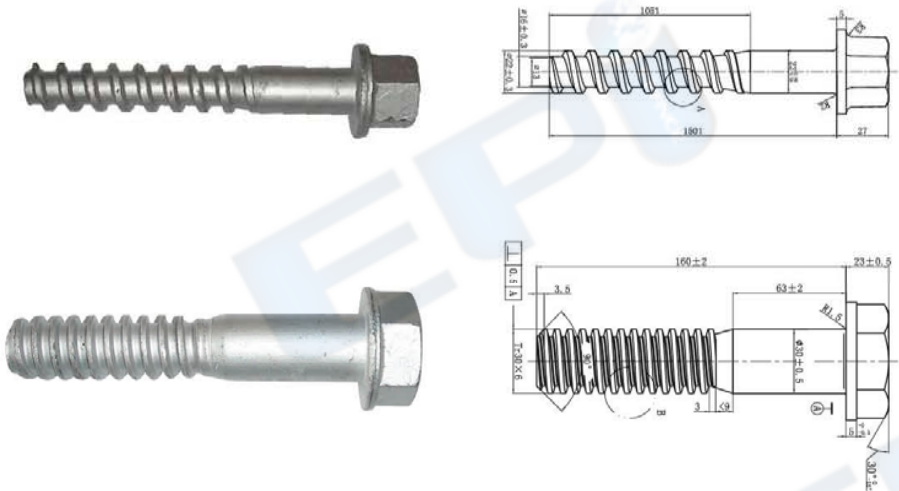

Tensile Strength	Yield Strength	Elongation	Reduction of area	Hardness	Bend test	Workmanship
120,000 psi min.	92,000 psi min.	14% min.	35% min.	HRc 22 min.-HRc 32 max.	Full size carbon steel screw spikes shall stand being bent cold 45° around a pin 3 times the spike's diameter without cracking on the outside of the bent portion.	Screw spikes shall be free from burrs, seams, laps, loose scale, irregular surfaces and any defects affecting their serviceability.

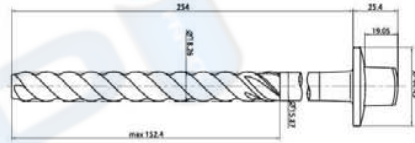
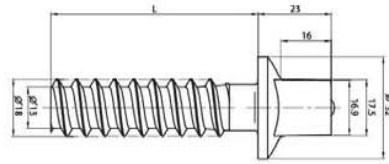

螺纹道钉 Screw spike

- 08) Coach screw
- 09) Dive spike
- 10) Screw spike ASTMA66-87
- 11) DHS35 screw spike

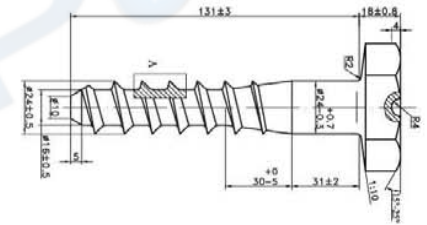
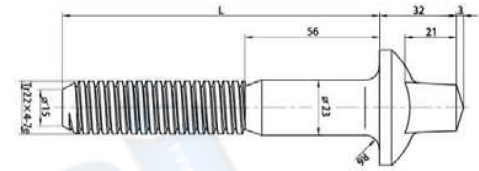

螺纹道钉 Screw spike

- 12) T type thread screw NF F500-15
- 13) Hex head screw spike
- 14) Special screw spike

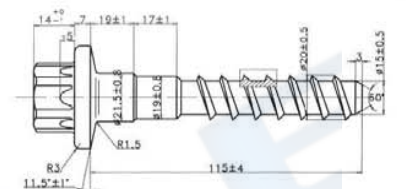
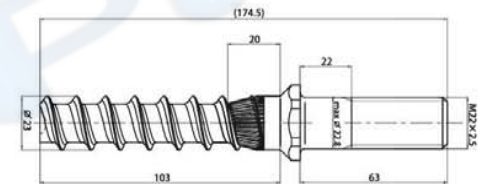
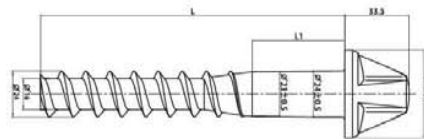
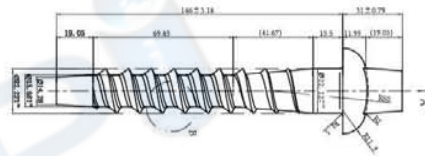

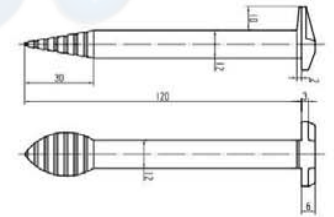
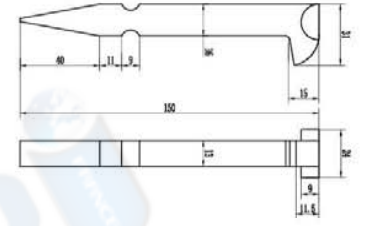
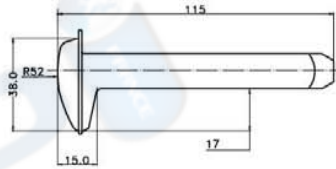
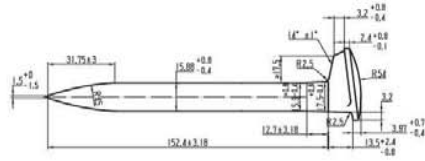

3 钩头道钉 Track spike

- 1) Track spike AREMA
- 2) Dog spike AS 1085.8
- 3) Rail spike Ss-EN10025
- 4) Boat spike

3 钩头道钉 Track spike

- 5) Special rail spike
- 6) Lock spike

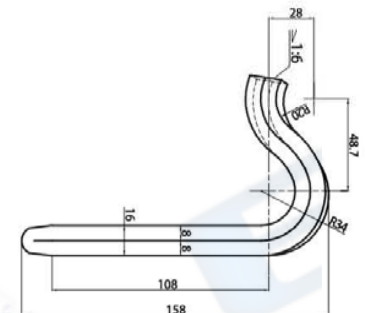
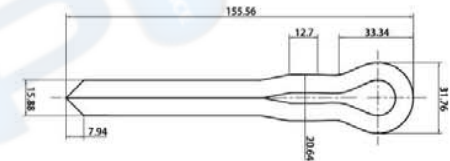
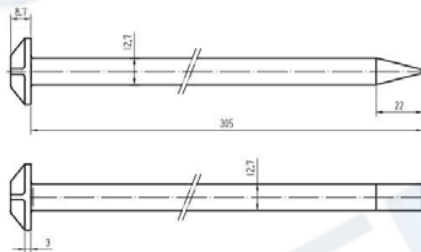

• 公司产品 (螺栓)
COMPANY PRODUCTS Bolt

4

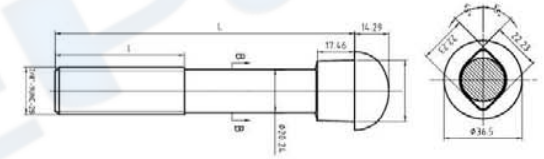
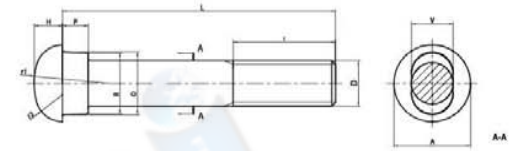

螺栓 Bolt

- 1) Button head oval neck track bolt
- 2) Diamond neck track bolt
- 3) Rail bolt NF F50-008
- 4) Clip bolt with BSW thread

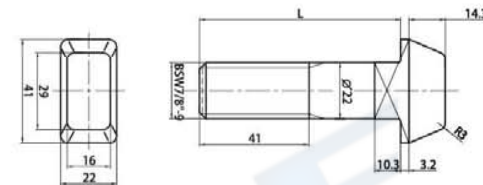
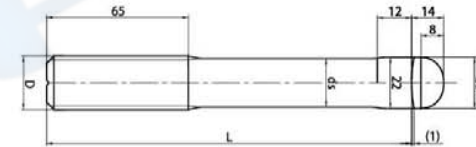



螺栓 Bolt

11) Special bolt

螺栓 Bolt

12) Anchor bolt

I type



L type

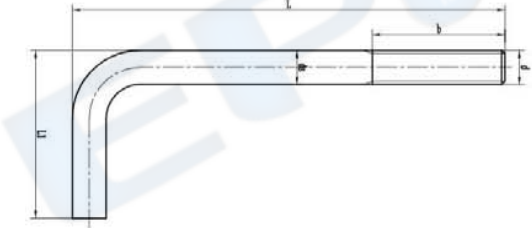

Fishtail bolt

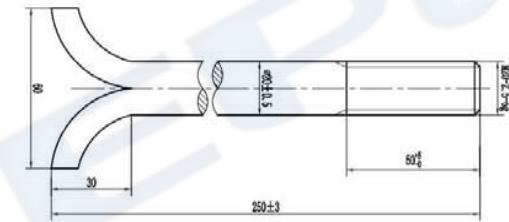

J type

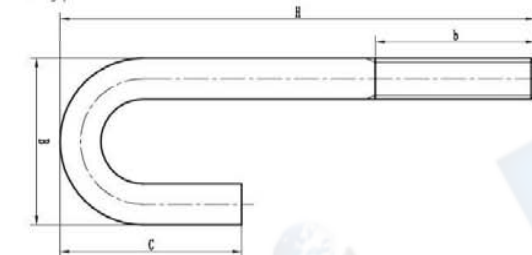

Square flange bolts with round thread for tunnel

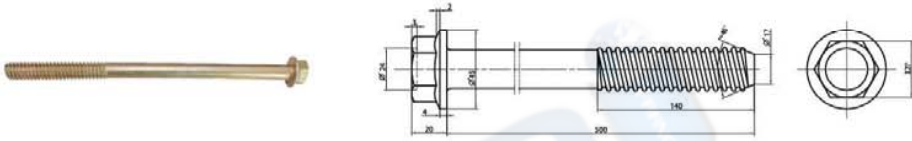

螺栓 Bolt

13) Tunnel Bolt

curve bolt for tunnel

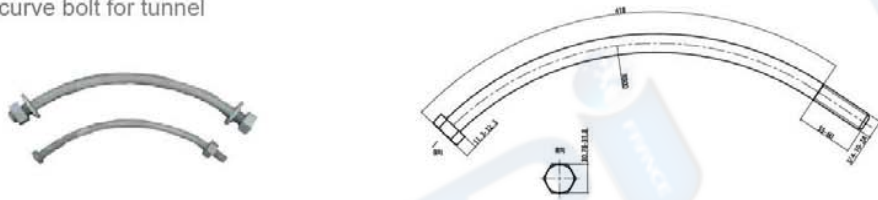

Spear bolts for tunnel

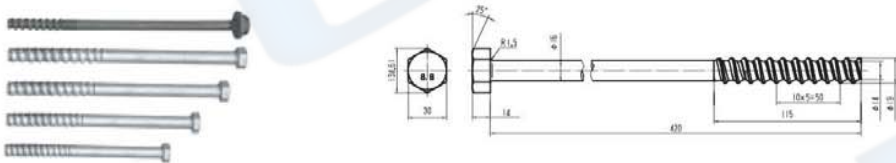

• **公司产品** (弹条) •
COMPANY PRODUCTS Elastic clip

5

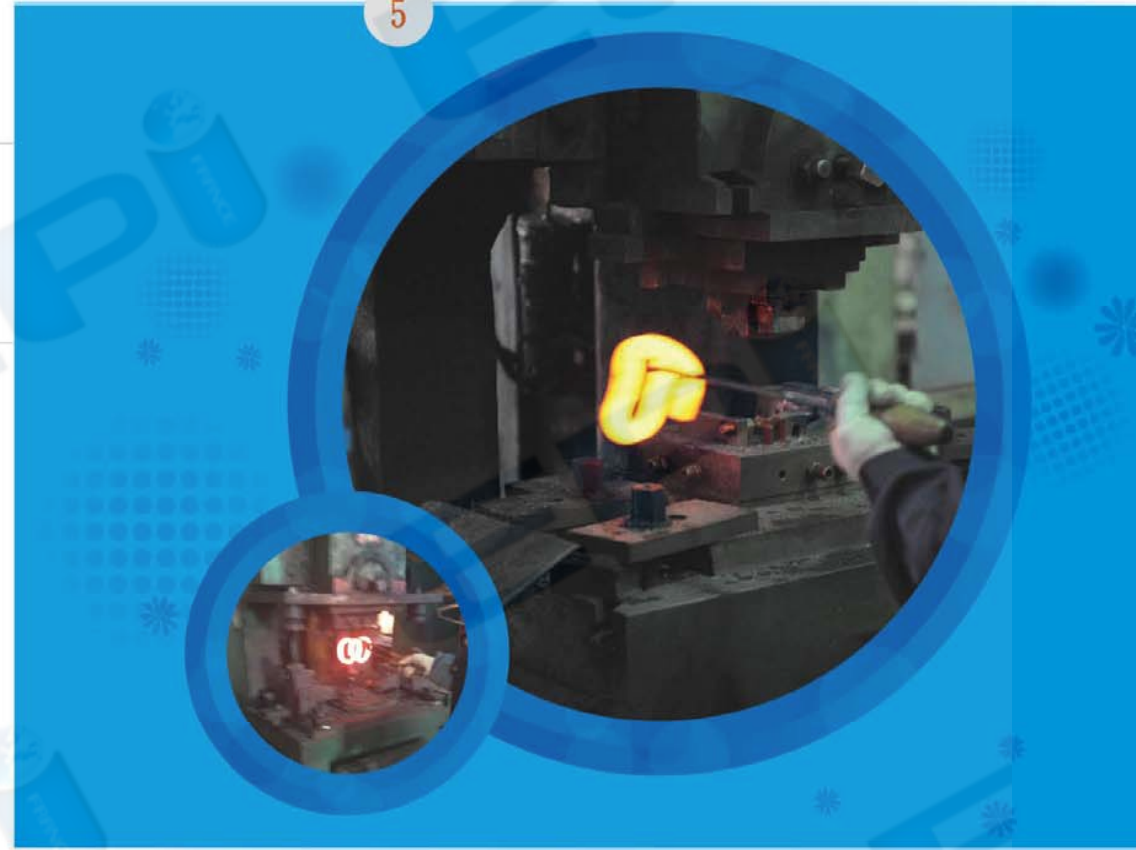

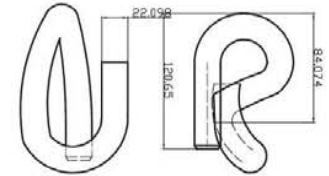
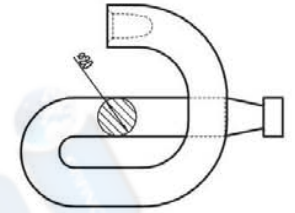
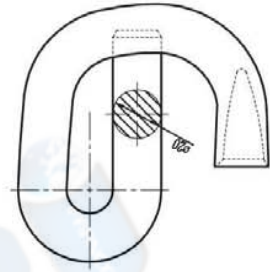

弹条 Elastic clip

- 1) E type clip with the diameter from 12mm to 20mm
- 2) Special clip

弹条 Elastic clip

- 3) Special E type rail clip
- 4) PR series Elastic clip
- 5) SKL1 Tension clamp
- 6) SKL3 Tension clamp

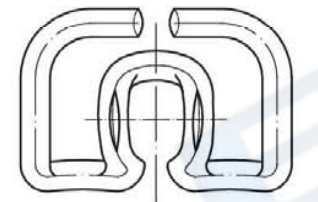
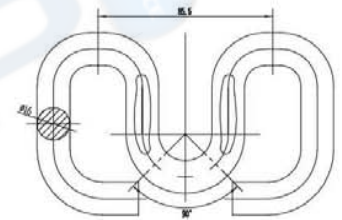
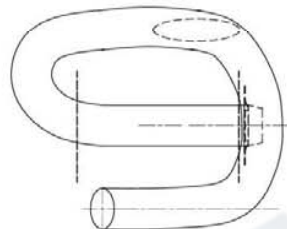
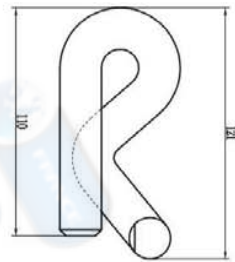

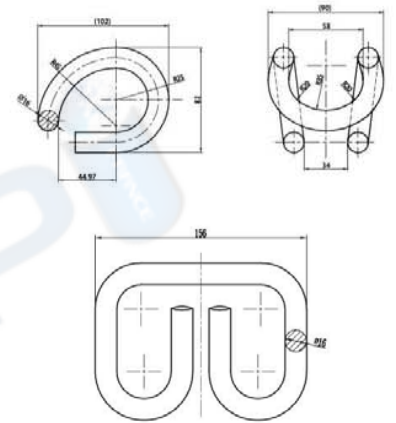
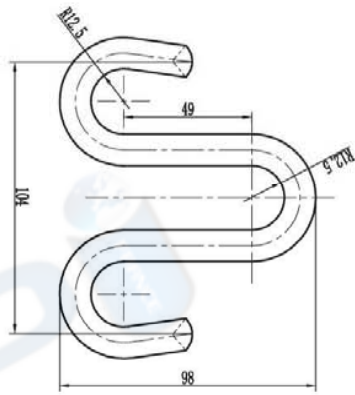

弹条 Elastic clip

- 7) SKL2 Tension clamp
- 8) SKL12 Tension clamp
- 9) SKL14 Tension clamp

弹条 Elastic clip

- 10) Deenik clip
- 11) Russian clip
- 12) Gauge lock clip
- 13) Fast clip

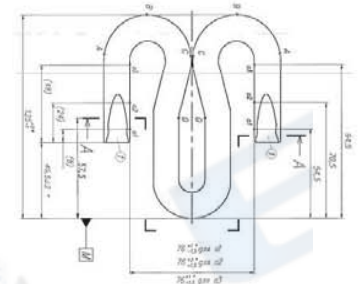
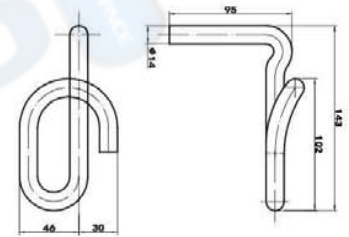
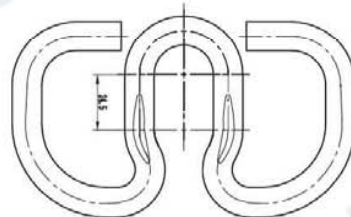
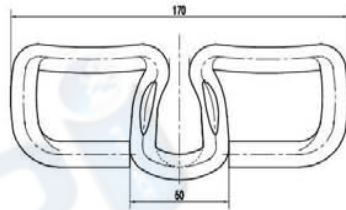

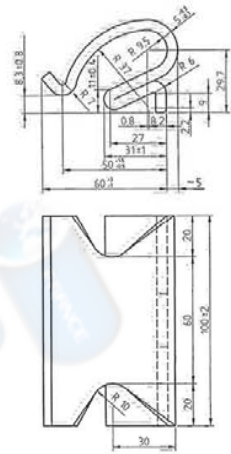

弹条 Elastic clip

- 14) Elastic plate
- 15) Elastic clamp
- 16) Nabla clip

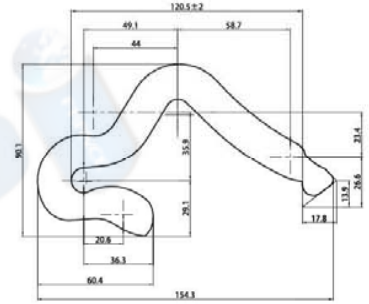

6 防爬器 Rail anchor

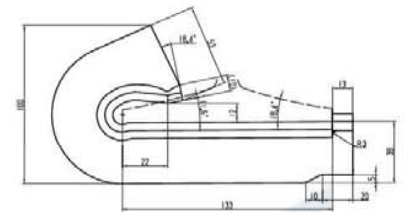
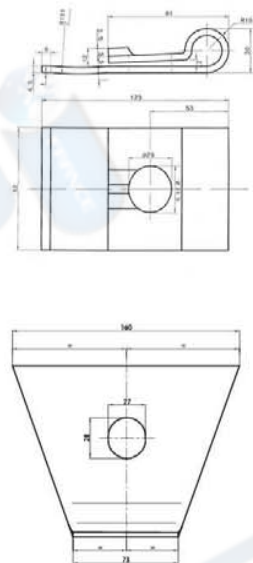

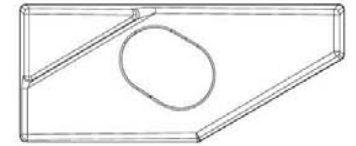
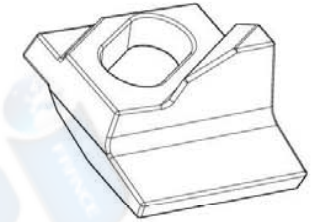
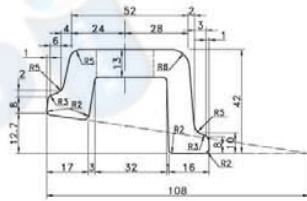
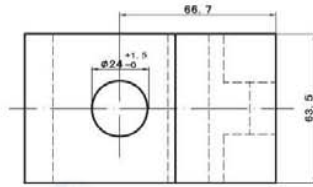

7 扣板 Rail clip

- 1) K Type Rail clip
- 2) KPO Rail clip
- 3) MTH Clips
- 4) Rail clip for North Africa

7 扣板 Rail clip

- 5) Crane clip 21/050 AN/BN
- 6) Crane clip 22/130 AN/BN

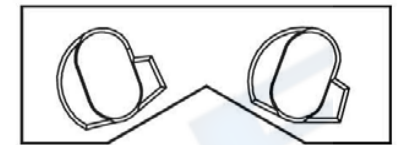
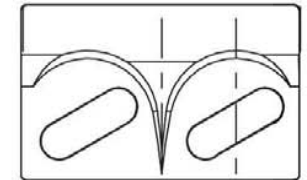
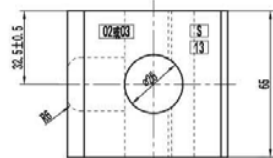
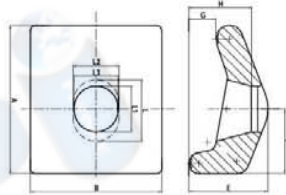



8 预埋件 Rail Shoulder

9 鱼尾板 Fish Plate



Standard	Type	Length / Diameter	Material	
AREMA 2007	115RE	4 hole - 24"	45# Chemical composition(%): C:0.42-0.50, Mn:0.50- 0.80, Si:0.17-0.37, Cr:≤0.25, P:≤0.035, S:≤0.035	50# Chemical composition(%): C:0.62-0.70, Mn:0.50- 0.80, Si:0.17-0.37, Cr:≤0.25, P:≤0.035, S:≤0.035
	115RE	6 hole - 36"		
	132-136RE	4 hole - 24"		
	132-136RE	6 hole - 36"		
UIC 864	UIC60	4 hole - 630 / \varnothing 26		
	UIC60	4 hole - 600 / \varnothing 28		
	UIC60	4 hole - 630 / \varnothing 25		
	UIC54	4 hole		
	UIC54	6 hole - 800		
	BS 47-1	BS75R		
BS80A		4 hole		
BS80A		4 hole		
BS90A		685.8 / \varnothing 26		
BS90A		792.9 / \varnothing 26 .2		
BS100A		4 hole		
AS	90/91LB	4 hole		
	90/91LB	6 hole		
	50Kg	4 hole		
	50Kg	6 hole		
	S49	4 hole		



10 铁垫板 Tie plate



10 铁垫板 Base plate



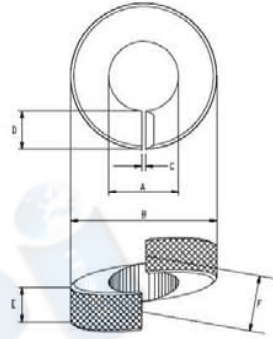

11 垫圈 Washer

- 1) Lock washer A.R.E.A 1967

11 垫圈 Washer

- 2) Flat washer ULS6 & ULS7
- 3) Double coil spring washer

NOMINAL BOLT DIAMETER	A		B		C NOM	D	E	F MAX	NET WT.PER 100 [LBS]
	MN	MAX	MN	MAX					
3/4	25/32	13/16	----	1-5/8	1/16	13/32	7/16	7/16	185
7/8	29/32	15/16	----	1-3/4	1/16	13/32	7/16	7/16	195
1	1-1/32	1-1/16	----	2-3/32	1/16	1/2	17/32	5/8	340
1-1/8	1-5/32	1-3/16	----	2-1/4	1/16	17/32	17/32	5/8	400
1-1/4	1-9/32	1-5/16	----	2-3/8	1/16	17/32	17/32	5/8	425
1-3/8	1-13/32	1-7/16	----	2-1/2	1/16	17/32	17/32	17/32	455

Spring Washers for Bolt Diameter Inches	Applied Load Pounds	Platens Released From Loads By Distances Inches	Minimum Reactive Spring Pressure Pounds
3/4	20,000	0.025	2,500
7/8	20,000	0.025	2,500
1	20,000	0.030	5,000
1-1/16	20,000	0.030	5,000
1-1/8	20,000	0.030	5,000
1-1/4	20,000	0.030	5,000

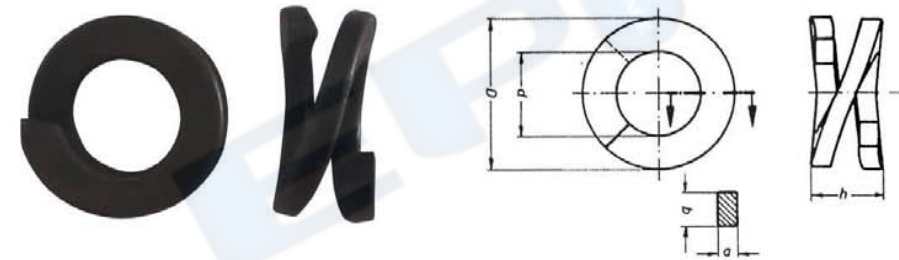

Item	d	D	a	b	h	KG
Fe6	25	45	6	10	19	0.09
Fe7	25	45	6	10	11	0.05
Fe8	21	39	5	9	16	0.058
Fe15	28	52	6	12	19	0.126
Fe19	26	46	6	10	25.5	0.145

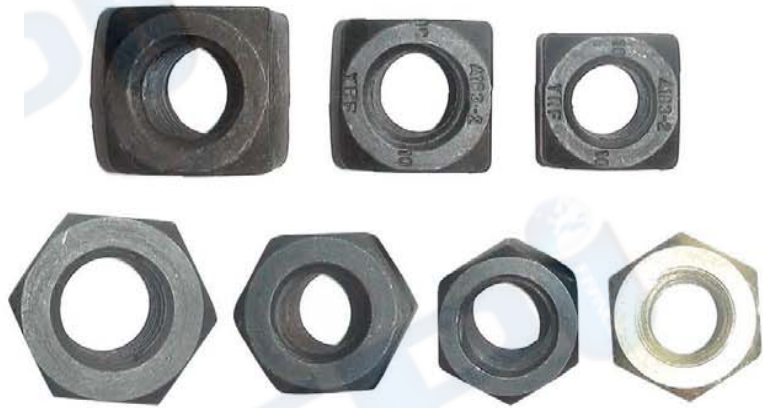

12 螺母 Nut

- 1) ASTM A-183 GR.2 Square heavy nut
- 2) Hexagon nut
- 3) Nylon lock nut
- 4) Special nut



13 塑料和橡胶制品 Plastic and rubber parts

- 1) Rail insulator, Guide plate, material is PA66





13 塑料和橡胶制品 Plastic and rubber parts

- 2) Plastic dowel, material is PA66 or HDPE
- 3) Rail pad, material is EVA, HDPE or Rubber

14 闸瓦 Brake block

- 1) Composite brake block
- 2) Cast iron brake shoe

Rubber Pad



EVA Pad



HDPE Pad





Size	Dimension(mm)				Weight (kg/m)	Material	Length (m)
	Head (mm)	Height (mm)	Bottom (mm)	Web (mm)			
A55	55	65	150	31	31.8	900A	10-12
A65	65	75	175	38	43.1	900A	10-12
A75	75	85	200	45	56.2	900A	10-12
A100	100	95	200	60	74.3	900A	10-12
A120	120	105	220	72	100	900A	10-12

15 起重轨 Crane rail

- 1) Crane rail DIN536
- 2) Chinese standard crane rail YBT5055-93
- 3) Grooved rail EN14811:2006



Size	Dimension(mm)				Weight (kg/m)	Material	Length (m)
	Head (mm)	Height (mm)	Bottom (mm)	Web (mm)			
QU70	70	120	120	28	52.8	U71Mn	12
QU80	80	130	130	32	63.69	U71Mn	12
QU100	100	150	150	38	88.96	U71Mn	12
QU120	120	170	170	44	118.1	U71Mn	12

Size	Dimension(mm)							Weight (kg/m)
	Height (mm)	Bottom (mm)	Head A (mm)	Head B (mm)	Channel A (mm)	Channel B (mm)	Web (mm)	
59R1	180	180	113	56	42	15	12	58.97
59R2	180	180	113	55.83	42.52	14.65	12	58.14
60R1	180	180	113	56	36	21	12	60.59
60R2	180	180	113	55.83	36.34	20.83	12	59.75

